

audiopraise

# *VANITY HD series*

## *Settings Guide*

Vanity<sup>93</sup> HD

Vanity<sup>103</sup> HD

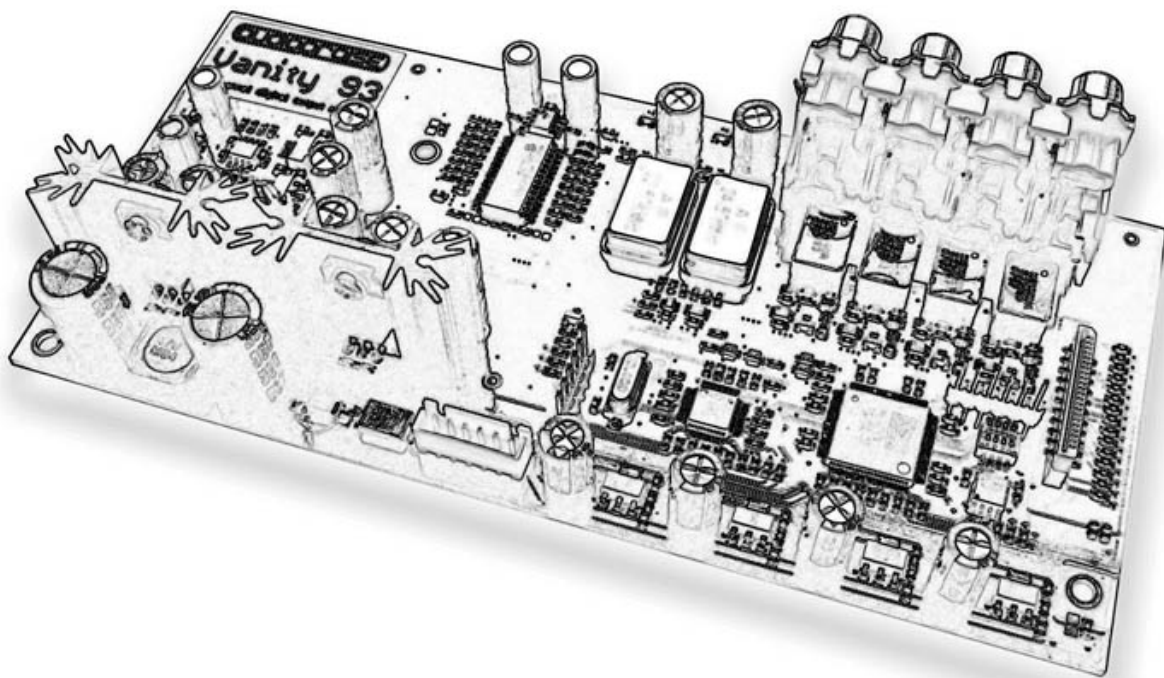

## Introduction

The Vanity HD module employs advanced multichannel audio signal processing for digital DSD playback with several parameters configurable by the user. To unlock the full potential of the product, the Oppo BDP-93/103 player has to be setup properly as well.

## Connection

The 8 channel digital output of the Vanity HD module is provided on the 4 red RCA connectors, each carrying 2 channels within a standard S/PDIF signal. The white connectors are not connected internally.

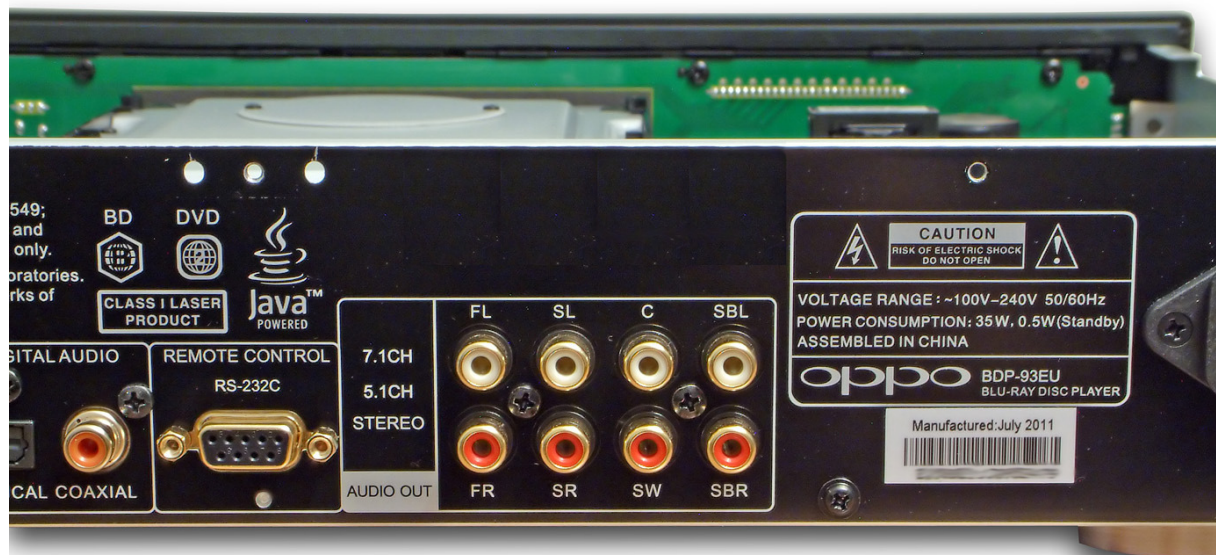

The arrangement of digital output connectors is similar to the original channel mapping of analogue outputs. Channels transmitted in each S/PDIF output are denoted by labels placed under and above the connector. The first connector from the left carries both front channels, the second carries the surround channels, the third carries the center and subwoofer channels and finally the fourth contains the surround-back channels.

## Vanity HD Setup

For digital SACD playback, the user can set the output sample rate, bit depth, conversion filter characteristics and a dedicated 4.0 DSD down-mix function using the onboard switches. These can be carefully operated by tweezers or a toothpick.

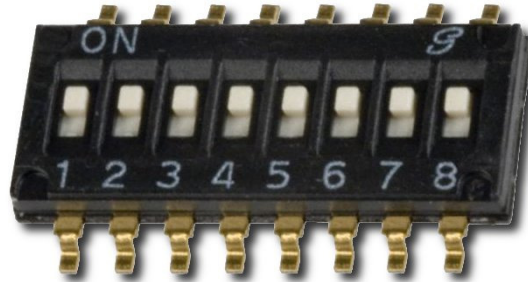

- Switch 1 - output sample rate 88.2 kHz or 176.4 kHz (ON)
- Switch 2 - output bit depth 16 bit or 24 bit (ON)
- Switch 3 - dedicated filter sets for 176.4 kHz enabled (ON) or disabled
- Switch 4 - conversion filter characteristic #1 (ON) / #2 or #3 (ON) / #4
- Switch 5 - onboard 4.0 DSD down-mix enabled (ON) or disabled
- Switch 6 and 7 - compatibility setting of the S/PDIF output
- Switch 8 - no function, leave OFF

Switch 1 selects the output sample rate between 88.2 kHz and 176.4 kHz. If the switch is set to the OFF position, the 88.2 kHz sample rate is used, Switch 3 has no effect and filter characteristic #1 or #2 can be selected. With Switch 1 set to the ON position, the output sample rate is set to 176.4 kHz. Furthermore, Switch 3 becomes active, enabling the user to select filter characteristic #3 or #4 dedicated for the 176.4 kHz sampling frequency. With Switch 3 left in the OFF position, filter characteristic #1 or #2 is used also for the 176.4 kHz output sample rate. The filter characteristics differ in their steepness. Sets #1 and #3 have a relatively fast roll-off, while sets #2 and #4 have slower roll-off characteristic. The best sounding filter set should be evaluated in each specific audio chain configuration. The dependencies between switches are summarized in the table below.

Switch 1	OFF		ON			
Switch 3	IRRELEVANT		OFF		ON	
Switch 4	OFF	ON	OFF	ON	OFF	ON
Output	88.2kHz #2	88.2kHz #1	176.4kHz #2	176.4kHz #1	176.4kHz #4	176.4kHz #3

Switch 2 sets the output bit depth to 16 or 24 bits. The 16 bit option can be useful for owners of so called non-oversampling (NOS) DACs or older devices designed to accept a 16 bit word length. In all other cases the 24 bit option – Switch 2 in ON position – should be used.

Switches 6 and 7 enable the user to modify the structure and certain synchronization elements of the S/PDIF protocol, which can have an impact on sound (so-called data jitter). Four setting configurations are available in total, as some S/PDIF receivers may not work with some of the available settings. The setting combinations have to be tested by trial and error. With both switches in the OFF position, the output is set to a standard format compatible with all receivers.

In most situations, the best performance is obtained with the following switch settings: S1–S4 ON, S5–S7 OFF.

The Vanity HD module does not alter the audio data during PCM playback (CD, DVD, BD media). Data is sent to the output directly. All signal processing tasks, such as down-mix, speaker distance adjustments, etc. are provided by the player. Please refer to the BDP–93/103 User Manual, section Audio Processing.

## **SACD Output Mode**

For SACD discs, the player offers two operation modes, PCM and DSD. High quality DSD to PCM conversion is performed by the Vanity HD module only when the player is set to the DSD mode. Please refer to the BDP–93/103 User Manual, section Audio Format Setup.

The DSD to PCM conversion algorithm implemented in the Vanity HD module sets 0dB SACD level equivalent to –3dB(FS) PCM level. This approach preserves maximum quality, provides sufficient headroom for clipping-less signal peaks, and still does not unnecessarily reduce playback volume in comparison to PCM playback.

When a HDMI connection with other down-stream devices is established, the player switches into PCM mode and the DSD to PCM conversion is handled internally by the player, in order to provide properly

down-mixed audio signal for the HDMI connection. This can be overcome by powering down the down-stream HDMI devices or disabling the HDMI audio in the player's menu. Such a behavior is not described in the BDP-93/103 User Manual and should be verified for each specific setup with onboard LED indicators.

## DSD 4.0 Down-mix

To achieve the best performance during digital SACD playback, it is essential to avoid the DSD to PCM conversion performed by the player. For this reason, the widely used 4.0 speaker configuration is covered by the dedicated down-mix algorithm implemented in the Vanity HD module. The algorithm preserves the overall signal level balance between channels and it can be described as follows.

$$FL_{mix} = 0.5FL + 0.25C + 0.25SW$$

$$FR_{mix} = 0.5FR + 0.25C + 0.25SW$$

$$SL_{mix} = 0.5SL$$

$$SR_{mix} = 0.5SR$$

In order to fit the mixed Center and Sub-Woofer channels into the front channels, the overall signal level is shifted by -6dB. No additional signal normalization or scaling is applied. Since the down-mix processing is carried out with full precision, there is no adverse effect on sound quality such as reduced dynamics or worse noise figures. Multi-channel SACD priority and 5.1 speaker configuration should be set in the player's menu before using the 4.0 down-mix function.

## LED Indicators

To easily distinguish between the DSD and PCM mode, there are 2 LEDs present on the Vanity HD module, indicating the current mode. These are located next to the FPGA chip as shown in the board diagrams below for Vanity<sup>93</sup> HD and Vanity<sup>103</sup> HD.

When the module is in PCM mode, the green LED is ON, while the red LED indicates DSD mode. There are also two LEDs next to the processor chip (the CPU). Alternate flashing of these LEDs indicates communication of the

CPU with the player and the FPGA chip. Synchronous flashing indicates adjustments of the local oscillators' frequency.

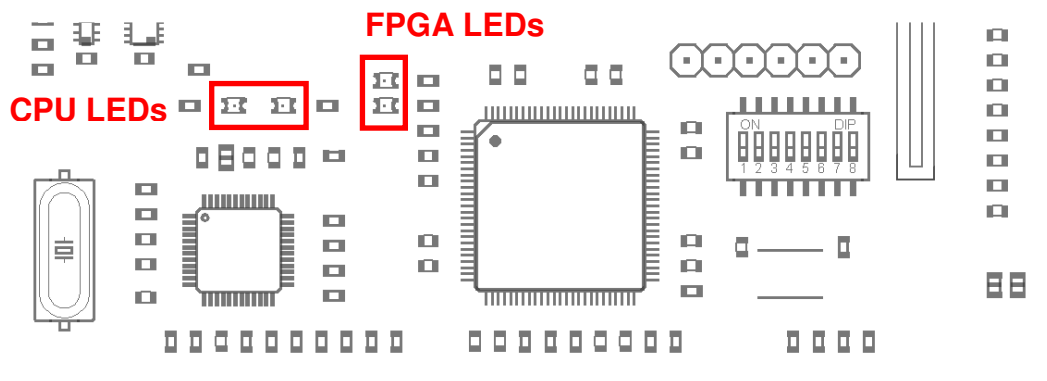

Vanity<sup>93</sup> HD LED locations

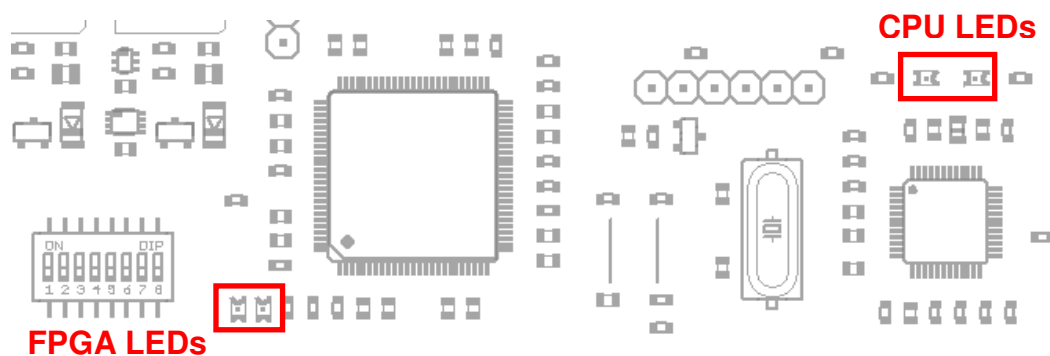

Vanity<sup>103</sup> HD LED locations

Adjustments of the local oscillators are usually more frequent in a short period after player start-up, due to the temperature stabilization of all clock related components.

Should you need any information beyond this settings guide, don't hesitate to contact us via email or have a look at our forum.

[ap@audiopraise.com](mailto:ap@audiopraise.com)

<http://www.audiopraise.com/forum/>

## Disclaimer

Audiopraise and its partners accept no responsibility for damage to the player, voiding your warranty or personal injury. Always unplug the power cable before removing the top cover. Follow the electrostatic discharge precautions when manipulating with electronic boards and components.

## Specifications

### 8 channel S/PDIF Output

- protocol: S/PDIF (IEC958 / EIAJ CP1201)
- type: re-clocked transformer isolated RCA coaxial
- format: linear PCM stereo
- supported sampling rates: 44.1 / 48 / 88.2 / 96 / 176.4 / 192kHz
- supported bit depths: 16 / 24bit

### S/PDIF Reclocking

- 2x custom low jitter onboard VCXO
- digitally controlled frequency tuning,  $f_c < 1\text{Hz}$
- ultra low-noise power regulators for VCXO and TX circuits

### High Quality Direct Stream Digital to Linear PCM Conversion

- custom developed Zero Alias Linear Phase Filter
- 37bit arithmetic / 47bit accumulator
- output sample rates: 88.2kHz / 176.4kHz
- DSD to LPCM filter characteristics individual for both output sample rates
- full precision 4.0 DSD down-mix option

### User Configurable Functionality

- DSD to LPCM output sampling rate: 88.2kHz / 176.4kHz
- output bit depth settings: 16 / 24bit
- dedicated DSD 4.0 down-mix enable / disable
- 4 user selectable DSD to LPCM filter characteristics #1 / #2 / #3 / #4
- data jitter reduction: OFF/stage 1–3